

Parallel

- Motor operation
- Provides all-around natural ventilation
- Facilitates smoke egress
- Enables smooth sight lines to be retained
- Composite stainless steel and plastic slides for strength, durability and smooth operation
- Tested to 10,000 cycles
- Maximum weight capacity 220 kg





The parallel hinge is a revolutionary hinge which has been specially designed for commercial buildings. It has been designed to allow windows to open and close in a parallel motion, without losing the reflective design of the building.

The motor operation will allow for simultaneous opening and closing of the window, allowing for natural ventilation and smoke egress, when the window is fully disengaged.

The parallel hinge is capable of carrying a weight load of 220kg, providing not only the strength required but also durability and smooth operation.

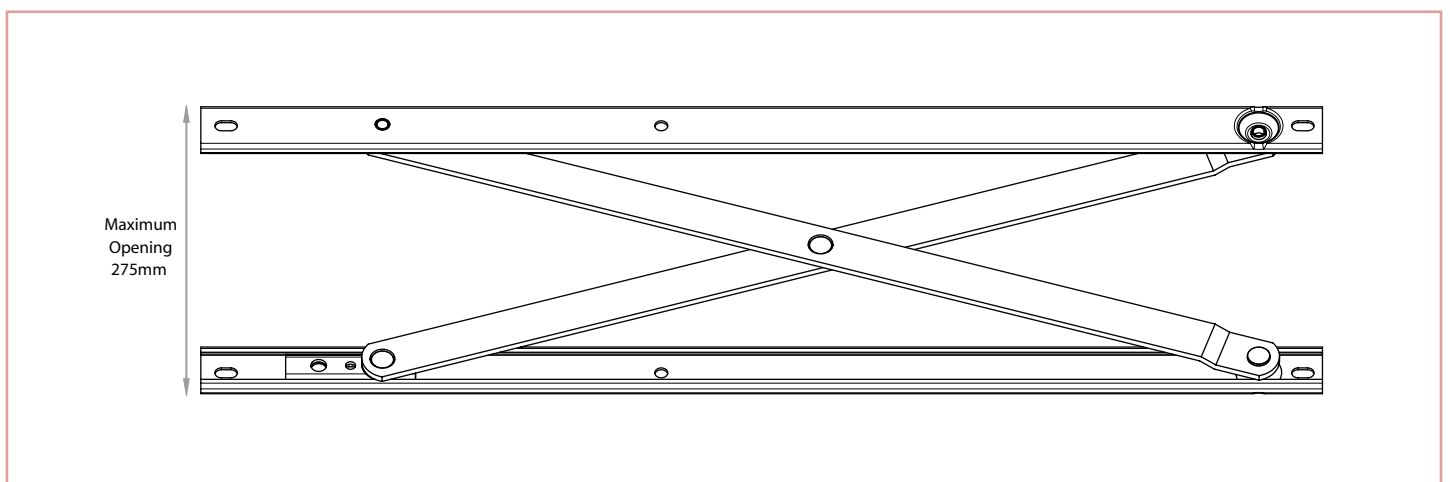

<i>Window Option</i>	<i>Height (mm)</i>	<i>Width (mm)</i>	<i>Weight (Max kg)</i>	<i>Hinges</i>	<i>Control Stay</i>	<i>Motors</i>	<i>Max Opening (mm)</i>
45.2000.00.001	500 – 1000	500 – 1000	60	2	1	n/a	275
45.2000.00.002	500 – 1500	500 – 1500	80	2	1	2	275
45.2000.00.003	1000 – 2000	500 – 1500	120	4	1	2 or 4	275
45.2000.00.004	500 – 1500	1500 – 3000	100	4	1	4	275
45.2000.00.005	1000 – 3000	1500 – 3000	220	4	2	4	275